

## DIN 562 Specifications

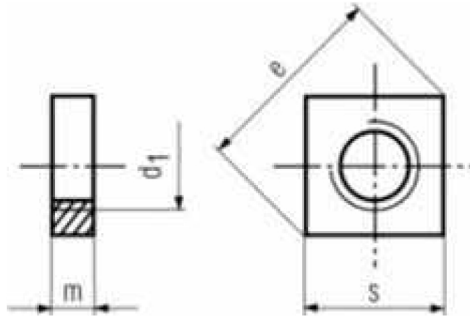

All measurements in millimeters (mm)

$d_1$	$s$	$e$	$m$
M3	5.5	7	1.8
M4	7	8.9	2.2
M5	8	10.2	2.7
M6	10	12.7	3.2
M8	13	16.5	4
M10	17	21.5	5

All information is strictly informative

